

# **X-Linked Dominant Manic-Depressive Illness: Linkage with Xg Blood Group, Red-Green Color Blindness, and Vitamin B12 Deficiency**

**Christopher M. Reading, B.Sc., M.B., B.S., M.R.A.N., Z.C.P. 1**

*Some of the literature describing X-linked dominant manic-depressive illness is reviewed. A family with manic-depressive illness, red green color blindness, Xg blood group, and vitamin B12 deficiency, all located on the same X chromosome through four generations, is described.*

*In the family studied the gene for manic-depressive illness and the gene for vitamin B-12 deficiency occupy the same locus, and it is proposed that the X-linked manic-depressive illness is very much associated with an X-linked metabolic disturbance resulting in vitamin B-12 deficiency.*

*The data very much support previous findings that manic-depressive illness can be sex-linked dominant and that bipolar and unipolar illness within the same family are genetically related and express the same genotype.*

*It is the first pedigree linking Xg blood group, red-green color blindness, manic-depressive illness, and a correctable sex-linked metabolic disturbance favorably improving the affective illness, all on the same X chromosome through four and possibly five generations.*

*It should encourage research into other X-linked metabolic disturbances in manic-depressive illness, especially X-linked B-group vitamin-dependent states (B6, B1, and B12 in particular). Lithium-like action of B-group vitamins and their synergism with lithium should also merit further research.*

## **Introduction**

Mendlewicz and Fleiss (1974) reviewed the literature suggesting that an X-linked dominant gene may be involved in the transmission of manic-depressive illness. Linkage studies using Xg blood group (a dominant X-linked trait) and color-blindness (a recessive X-linked condition) were carried out by Winokur et al. (1969), and Fieve et al. (1973). Mendlewicz and Fleiss (1974), using

**· Formerly Psychiatrist, North Ryde Psychiatric Centre, Sydney, Australia.**

**Address for Reprints: Dr. Chris Reading, 10 Ian Avenue, North Curl Curl, N.S.W., 2099, Australia.**

similar genetic markers, concluded that within the families described in their study, a dominant X-linked gene is involved in the transmission of bipolar (manic-depressive) illness while X-linked inheritance could be ruled out as the mode of transmission in unipolar (depression only) illness. They point out that the close linkage between bipolar illness and the color blindness loci, and the less close linkage of bipolar illness and the Xg blood group, are consistent with data published by Renwick and Schulze (1964), indicating that the loci for Xg blood group and color-blindness are far apart. Thus the locus for bipolar illness appears to be between the Xg locus and the colorblindness loci, closer to the latter.

Manic-depressive illness is not uncommon, results in frequent admissions to psychiatric hospitals, sometimes requires psychosurgery, and is one of the main psychiatric disorders leading to suicide (Winokur and Tsuang, 1975). In fact, a manic-depressive disorder is a major cause of 45 to 55 percent of suicide deaths, a figure that rises to 87 percent in the elderly, (Whitlock, 1974).

At a Symposium on depression in Washington sponsored by the National Association for Mental Health, depressive illness was found to affect one out of every 10 Americans and costs the USA an estimated \$5 billion annually in both treatment and lowered productivity. At the American Medical Association's 122nd Annual Meeting (New York) Dr. Ronald R. Fieve claimed that manic depression is "probably the most widespread of all psychiatric illnesses" affecting at least 20 million Americans annually. One-fifth don't respond to lithium treatment.

Thus if some X-linked, possibly reversible, metabolic disturbance could be found in manic-depressive illness, it could shed light on the etiology of this condition, and the cost benefit would be enormous.

Recently a hereditary form of depressive illness running in three successive generations of a family in an autosomal dominant fashion and not responsive to antidepressant drugs or electroconvulsive therapy (ECT), and later leading to Parkinsonism, was investigated biochemically.

Taurine was found to be greatly diminished in the plasma and C.S.F., and it was postulated that the deficiency of brain taurine may possibly have caused the psychiatric and neurological manifestations of the disorder (Perry et al., 1975).

Similarly, a group of chronic psychiatric

inpatients with chronic affective disorder (manic-depressive illness, schizoaffective psychosis, periodic psychosis) unresponsive to lithium, antidepressants, and ECT was investigated by the author (to be published). Vitamin profiles were carried out along with psychometric testing prior to and after six months' therapy. The patients with low vitamin B-12 (and normal hemoglobin and film) improved with parenteral vitamin B-12 replacement therapy.

Since pernicious anemia and manic-depressive illness are closely associated in some families (personal observation) and vitamin B-12 deficiency may result in depression, mania, or other affective disturbances (Reading, 1975a, 1975b, 1975c), a possible link between the two conditions seemed worthy of further research hoping that the findings would be important for the primary, secondary, and tertiary prevention of the condition.

As manic-depressive illness has been shown to be inherited in an X-linked dominant fashion in some families (Mend-lewicz and Fleiss, 1974), and X-linked metabolic disturbance<sup>^</sup> that can cause depression or mania in these families could be very important in the etiology and treatment of the condition.

One large manic-depressive family with pernicious anemia informative for linkage studies *has been* looked at to determine the following:

- (1) Was the manic-depressive illness linked to red-green color-blindness and Xg blood group, as in previous studies mentioned?
- (2) Was the pernicious anemia linked to red-green color-blindness and Xg blood group and thus X-linked, as it is usually regarded as autosomal recessive (Furuhjelm and Nevanlinna, 1973)?
- (3) Should the above prove true would parenteral vitamin B-12 correct or

improve the affective illness?

- (4) Could the gene site (locus) for manic-depressive illness be at the same locus on the X chromosome as a vitamin B12 metabolic disturbance in some families?
- (5) Are there other X-linked metabolic factors that need to be considered, such as pyridoxol B6, thiamine B-1, and niacin B3 in X-linked affective illness?
- (6) Would the study support the concept that bipolar and unipolar illness within a family are genetically related and express the same genotype as suggested by Fieve et al., (1973)?

### Materials and Methods

Key members of a family with manic-depressive illness and pernicious anemia had psychiatric interviews, answered questionnaires relating to psychiatric illness and pernicious anemia, and underwent routine pathology tests. Most of the information came from the proband's first-degree relatives, two sisters and a brother, and especially from her 86-year-old mother (an active, highly intelligent, lucid, ex-lecturer in chemistry with a Master of Science Degree) with an excellent memory of her grandparents and her husband's grandparents and family, as she married her maternal uncle's son (after her sister, who had been married to him, died in an accident). The proband's deceased sister's son was also interviewed and examined. The proband had been under close study for over four years.

**Color-blindness:** The family was tested with Ishihara plates (accurate enough to detect the severe protanopia in the family).

**Xga - blood group:** Analysis was done blindly by Mr. J. Ruxton of the Oliver Latham Laboratory.

**Manic-depressive illness:** Members of the family were euthymic at the time of interviews. The diagnoses of bipolar (manic-depressive) and unipolar (depressive) illness were made using criteria similar to those of Winokur et al. (1969). Hospitalization was not required for either diagnoses, but each

individual's normal activities must have been disrupted for at least three weeks.

The following criteria were used for the diagnosis of bipolar manic-depressive illness:

- (1) Periodicity of illness with symptom-free intervals and no personality disintegration before or following psychotic episodes.
- (2) At least two episodes lasting three weeks or more that met the following criteria for mania:  
hyperactivity, euphoria, grandiosity, pressure of speech, flight of ideas, marked irritability, decreased need for sleep.
- (3) Episodes of depression characterized by depressed mood, the presence of guilt, decreased concentration, anhedonia, suicidal ideation with or without insomnia, anorexia and weight loss, alibido, anergy, diurnal mood variation.

It is assumed that within the family pedigree identified by a bipolar proband, bipolar and unipolar illness could be genetically related and express the same genotype (Fieve et al., 1973).

### Pernicious Anemia

A questionnaire was given to each member of the family inquiring about anemia and the symptoms and signs of pernicious anemia. Relatives with chronic anemia treated with parenteral vitamin B-12 and/or raw liver and diagnosed by their physicians as having pernicious anemia were regarded as suffering from the condition, especially when there was marked premature graying of hair (late teens, early twenties), broad forehead, gastrointestinal symptoms of achlorhydria, glossitis, and other such disturbances.

Serum vitamin B12 (Lactobacillus Leichmannii) assays were carried but on living members. In those members with low B-12 levels the following causes for the low B-12 were excluded:

- (1) **Increased requirement of vitamin B<sup>12</sup>:** Hyperthyroidism, polycythemia, neoplasm, and pregnancy—may result

in a low serum B-12 level. These conditions were not present.

(2) **Inadequate intake of vitamin B12:**

Unlikely as they ate normal diets and were not vegetarians or alcoholics.

(3) **Drugs:** Oral contraceptive agents, neomycin, methotrexate, and others known to result in low serum vitamin B-12 levels (Reading, 1975a and 1975b).

(4) **Inadequate utilization of vitamin B12:**

Vitamin B-12 antagonists, protein malnutrition, liver disease, pancreatic disease, renal disease, and other conditions (Reading, 1975a).

(5) **Lack of synergists** such as pantothenic acid, biotin, folic acid, and vitamins A, E, C, and B-1 or T4 (thyroxine) deficiency impairing absorption.

(6) **Gastrointestinal disorders:** Gastrectomy, disorders of the ileum (coeliac disease, steatorrhoea, tropical sprue, and regional ileitis), intestinal parasites (fish tapeworm), blind-loop syndrome (B-12-greedy bacteria), and disturbed calcium metabolism as seen in hypoparathyroidism impairing vitamin B-12 absorption, were considered and not detected in the family examined. None of the patients tested had intrinsic factor antibodies at pH 5), nor did any have an abnormal Schilling test result. None of those tested had proteinuria which is often seen in association with Imerslund—Najman—Grasbeck's disease. It is not known if the second binder in gastric juice (non- IF binder, rapid migrating binder, R binder, or Gras-beck binder) is absent, or non-functional in the family studied.

**Pathology tests**

Routine hematology and biochemical tests were performed including thyroid function tests to exclude organicity apart from vitamin B-12 deficiency.

**Results**

Proband IV 8. This single lady has a long history of affective illness (bipolar) extending over 35 years following an unwanted pregnancy and had spent most of her life in and out of institutions. She had been treated with insulin coma therapy, electroconvulsive therapy, tricyclic antidepressants, lithium, chlorpromazine, haloperidol, and other medications, all to no avail. After spending years in hospital she was discharged and remained well for over a year on lithium carbonate and IMI B12 monthly. Vitamin B-1 (thiamine) and B6 (pyridoxal) were also low and corrected. Niacin was low; however, she had received niacin before the vitamin profile was done.

She had appeared resistant to lithium carbonate, and neither lithium alone nor IMI B12 with or without B-1 and B6 were sufficient to prevent the mood swings; however, the intensity and duration of the mood swings were beneficially affected by the latter. Psychometric tests prior to vitamin therapy and after six months' treatment (measured both times while euthy-mic between phases) showed improved scores on the tests administered (for publication).

Other members receiving parenteral B-12-are in remission (V5 and IV7), and in II4 and III3 there was marked improvement in their affective illness (especially depressive phase) once pernicious anemia was diagnosed and treated.

**Discussion**

In the family studied, Xga blood group and red-green color-blindness were informative and allowed linkage studies to be carried out. The study supports X-linked dominant inheritance of manic-depressive illness in some families (Mendlewicz and Fleiss, 1974). They pointed out the close linkage between bipolar illness and the color-blindness loci, and the less close linkage of bipolar illness and the Xga blood group which is consistent with data

FIGURE 1

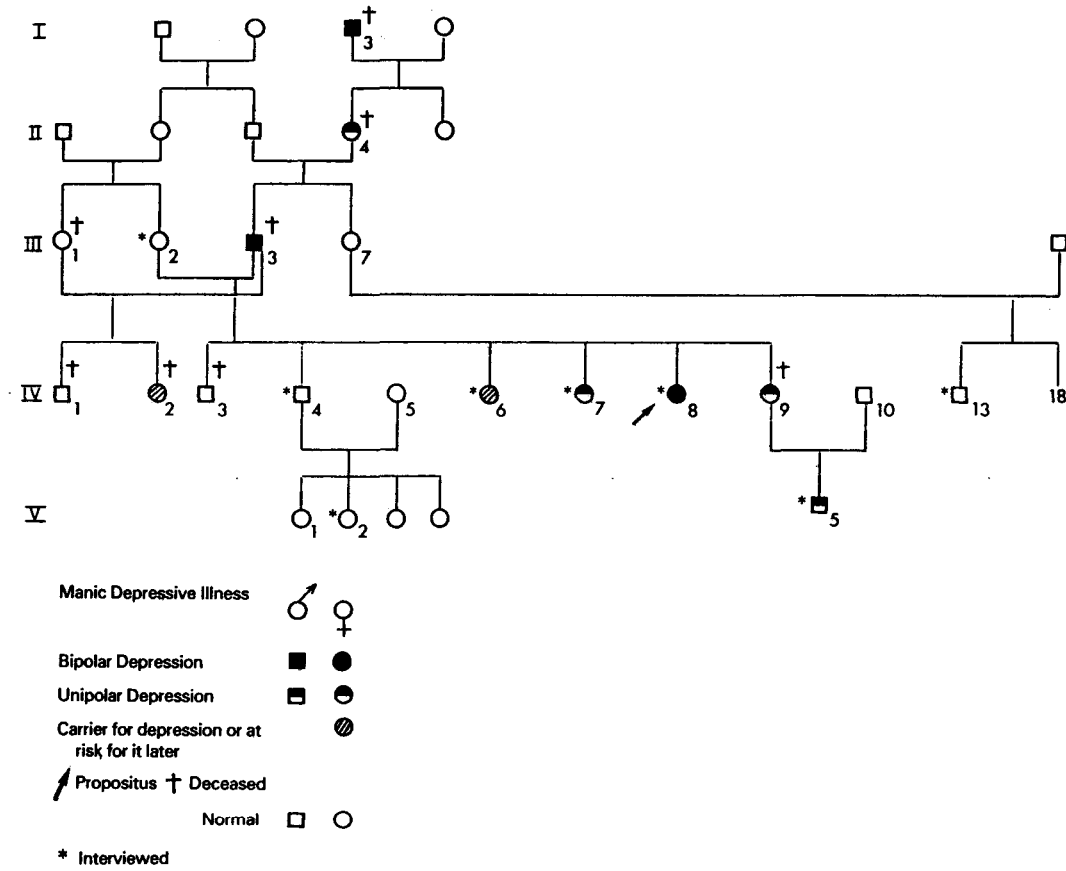
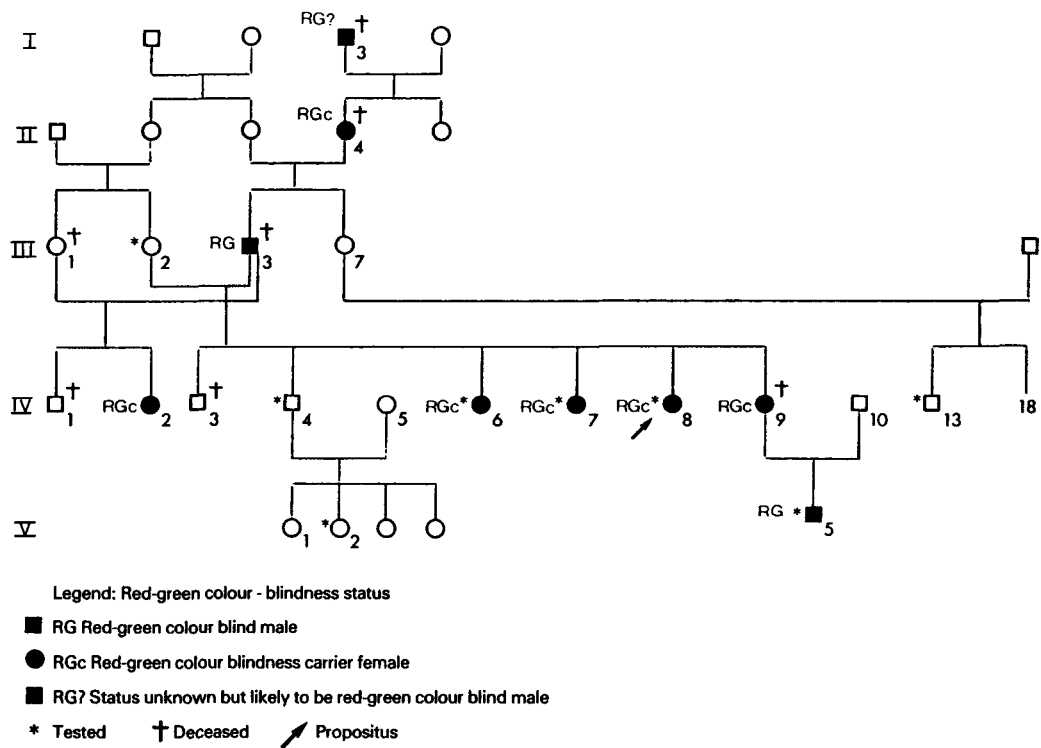
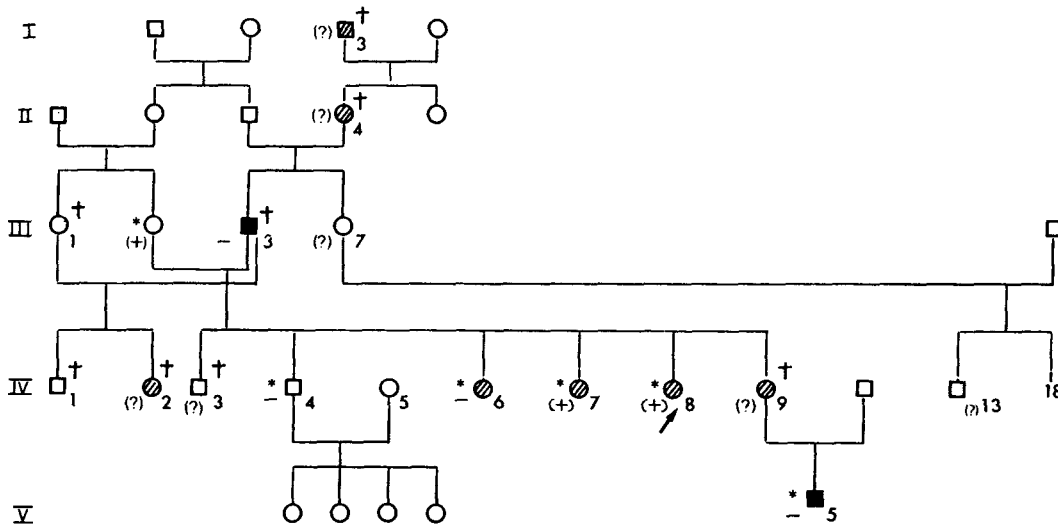

FIGURE 2



# X-LINKED DOMINANT MANIC-DEPRESSIVE ILLNESS

FIGURE 3



Xg status (lower left of symbols)

- + Homozygous, positive ( + ) Heterozygous
- Homozygous, negative ( ? ) Unknown status
- Xg<sup>-ve</sup> and red-green colour blind male
- ▨ Probably Xg<sup>-ve</sup> and red-green colour blind male
- ◐ Carrier for Xg<sup>-ve</sup> blood group and red-green colour blindness (female)
- \* Tested † Deceased / Propositus

FIGURE 4

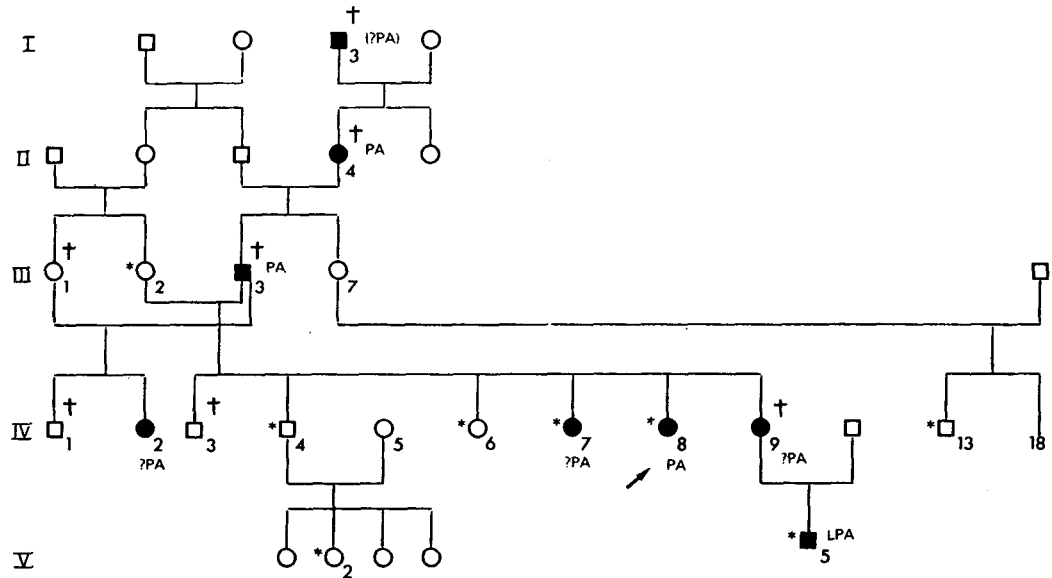

Vitamin B<sub>12</sub> Status

- ♂ ♀
- ● PA Pernicious Anemia
- ▨ ● LPA Latent Pernicious Anemia (low Vitamin B<sub>12</sub> without anemia)
- ◐ ● ?PA Anemia, probably pernicious anemia
- ◑ ● (?PA) Pernicious Anemia likely but unknown
- / Propositus \* Tested † Deceased

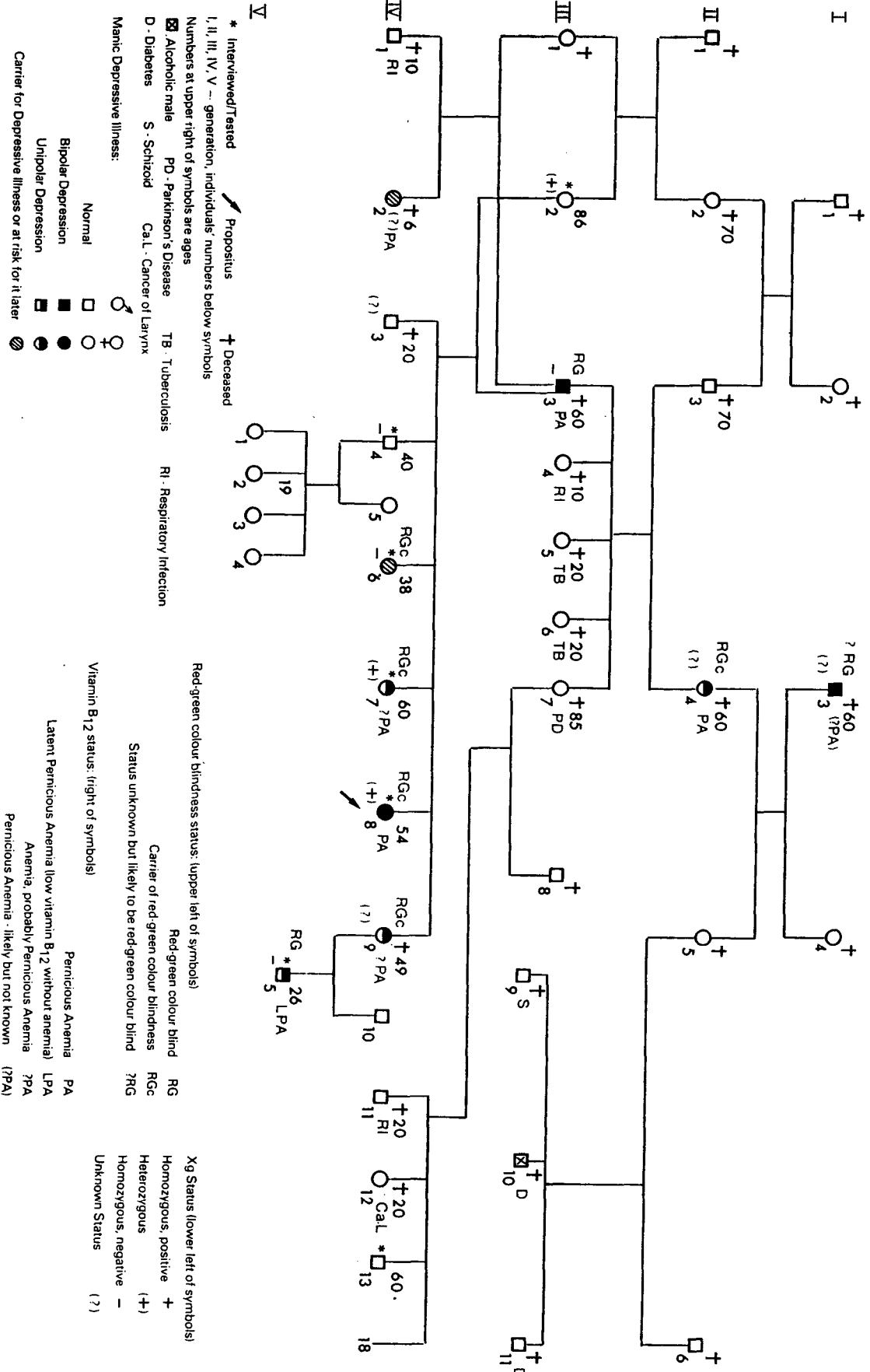

FIGURE 5

X-LINKED DOMINANT MANIC-DEPRESSIVE ILLNESS

| Generation       | Sex | Age  | Manic-Depressive illness                                | Red-green Colour-blindness | Xg <sup>a</sup> Blood Group  | Vitamin B <sub>12</sub> Level/Pernicious Anemia   | Hb.           | Folate    |
|------------------|-----|------|---|----------------------------|--|---|---------------|-----------|
| I <sub>3</sub>   | M   | † 60 | Bipolar   | ? Colour-Blind             | ? Xg <sup>a</sup> -ve (R/G ?Xxg <sup>a</sup> -ve Y)                          | ? Pernicious anemia. White hair by 30. Heart failure. Similar affective illness and phenotype as III <sub>2</sub>     | -             | -         |
| II <sub>4</sub>  | F   | † 60 | Unipolar  | Carrier                    | Carrier Xg <sup>a</sup> -ve  | Pernicious Anemia. Treated raw liver. White hair by 30.   | -             | -         |
| III <sub>2</sub> | F   | 86   | Active. Lucid. Stable lady. M.Sc.Ex-lecturer in Science | Normal                     | Heterozygous (+) (Xxg <sup>a</sup> +ve Xxg <sup>a</sup> -ve)                 | B <sub>12</sub> 434 pg/ml. No premature greying   | Not decreased | 4.9 ng/ml |
| III <sub>3</sub> | M   | † 80 | Bipolar   | Colour-Blind               | Homozygous - (R/G Xxg <sup>a</sup> -ve Y)                                    | Pernicious Anemia. White hair by 30. Indigestion main complaint. Heart failure  | -             | -         |
| IV <sub>2</sub>  | F   | † 6  | Pale delicate neurasthenic child                        | Carrier                    | Carrier Xg <sup>a</sup> -ve (R/G Xxg <sup>a</sup> -ve X?)                    | Pale, weak, chronically anemic - died of anemia aged 6. ? Pernicious anemia   | -             | -         |
| IV <sub>3</sub>  | M   | † 20 | Stable, killed in world war II                          | Normal pilot in war        | Unknown  | Unknown   | -             | -         |
| IV <sub>4</sub>  | M   | 40   | Normal  | Normal                     | Xg <sup>a</sup> -ve (-) not colour blind (Xxg <sup>a</sup> -ve Y)            | B <sub>12</sub> 233 pg/ml. No early greying or anemia   | 16.5          | -         |
| IV <sub>6</sub>  | F   | 38   | Carrier and at risk for affective illness               | Carrier                    | Carrier Xg <sup>a</sup> -ve (-) (Xxg <sup>a</sup> -ve ?Xxg <sup>a</sup> -ve) | B <sub>12</sub> 324. Premature greying not anemic yet (38)  | 14.9          | -         |
| IV <sub>7</sub>  | F   | 60   | Unipolar  | Carrier                    | Heterozygous (+) (Xxg <sup>a</sup> +ve Xxg <sup>a</sup> -ve)                 | B <sub>12</sub> 547 - had IMI B <sub>12</sub> for recurrent depression 2 years prior to assay                         | 16.6          | -         |
| *IV <sub>8</sub> | F   | 54   | Bipolar for over 30 years                               | Carrier                    | Heterozygous (+) (R/G Xxg <sup>a</sup> +ve Xxg <sup>a</sup> -ve)             | Very broad forehead, blue eyes, fair complexion, auburn hair went white by 30 B <sub>12</sub> 169 and 103. I.F. - ve. | 11.9          | 3.0 ng/ml |
| IV <sub>9</sub>  | F   | † 49 | Unipolar  | Carrier                    | Carrier Xg <sup>a</sup> -ve (R/G Xxg <sup>a</sup> -ve X?)                    | Recurrent depression anemia (? Pernicious anemia) died renal failure. Prematurely grey                                | -             | -         |
| IV <sub>13</sub> | M   | 60   | Normal  | Normal                     | Xg <sup>a</sup> status unknown but not colour blind                          | Assayed when admitted to hospital for encephalitis. B <sub>12</sub> 666   | 14.9          | -         |
| V <sub>2</sub>   | F   | 19   | Normal  | Normal                     | Xg <sup>a</sup> -ve carrier (Xxg <sup>a</sup> -ve X?)                        | B <sub>12</sub> 317 not anemic  | 14.5          | -         |
| V <sub>5</sub>   | M   | 26   | Unipolar  | Colour-Blind               | Homozygous - (R/G Xxg <sup>a</sup> -ve Y)                                    | B <sub>12</sub> 155 pg/ml and below 184 on 2 other occasions. Prematurely grey. I.F. - ve                             | 15.5          | 9.4 ng/ml |

\* Proband. † Deceased R/G: Red-green colour-blind Hb., Hemoglobin g%: Normal folate > 2.7 ng/ml  
 I.F. -ve No intrinsic factor antibody detected at pH 5.0.  
 Vitamin B<sub>12</sub> normal range 184 - 800 pg/ml

published by Renwick and Schulze (1964) indicating that the loci for Xg blood group and color-blindness are far apart, and thus the locus for bipolar illness appears to be between the Xg locus and the colorblindness loci, closer to the latter. In the family studied, the locus for affective illness is also likely to be between the red-green color-blindness locus and the Xg<sup>a</sup>-ve blood group locus. In the family studied a vitamin B<sub>12</sub> metabolic disturbance is also linked with manic-depressive illness, and without the B-12 metabolic disturbance the manic-depressive illness may not express itself as in IV6- There is no affective illness in III<sub>2</sub>, IV<sub>4</sub>, V<sub>2</sub>, and IV<sub>6</sub>, all of whom have normal B<sub>12</sub> levels. However IV<sub>6</sub> may well be a carrier for affective illness and is only 38. (IV<sub>6</sub> appears to be at risk for affective illness and B<sub>12</sub> disturbance as she carries an X<sup>a</sup> chromosome from her father who had the same

chromosome and bipolar manic-depressive illness and pernicious anemia). Also as members of the family diagnosed as having pernicious anemia or low B-12 without anemia showed marked improvement with treatment, it strongly suggests the locus for B<sub>12</sub> metabolic disturbance must be very close to, if not the same locus as that for manic-depressive illness and thus also between the locus for Xg<sup>a</sup>-ve blood group and red-green color-blindness. (A fifth trait may also be on the same X chromosome, namely tendency to premature graying in late teens or early twenties and white hair by 30. The association of premature graying



and pernicious anemia is well known.

The study also supports the concept that bipolar and unipolar illness within a family are genetically related and express the same genotype as suggested by Fieve et al. (1973). The proband IVs was also low in (pyridoxal) B6 which can also be X-linked (Horrigan and Harris, 1964), and it is known B6 deficiency and (niacin) B3 deficiency (pellagra) may mimic manic-depressive illness (Bar, 1969; Hawkins and Pauling, 1973), and recently a sex-linked niacin metabolic disturbance has been described (Hohn and Lehrer, 1975). As IV8 had been taking B3 prior to the vitamin assays, it is not known whether she had a niacin deficiency prior to treatment or not. (Niacin 1 g/day resulted in a manic confusional state). IVs also had low B-1 which can cause depression. (A vitamin profile in V5 was not informative as to whether there was also a B6 or B1 sex-linked vitamin deficient/ dependent state in the family as V5 had been on a multivitamin preparation containing B1 and B6 before the vitamin profile, and although B1 and B6 levels were normal, deficiencies may have been masked.) Other manic-depressive patients with low vitamin B-12 have also had low B-1 and B6 (Reading, 1975a) and over 80 percent of manic-depressive patients assayed for B1 and B6 have had deficiencies of both these vitamins (work to be published, and Reading, 1977) suggesting that these deficiencies may also play a role in the etiology or the expression of the illness (B12 deficiency occurs less often).

In three other families, pernicious anemia and manic-depressive illness appear in three generations in a sex-linked dominant form; however, red-green color-blindness does not occur and Xga linkage has not been studied yet. In another family the pernicious anemia patients have manic-depressive illness, but not all the manic-depressives have pernicious anemia; however, serum B12 levels to exclude latent pernicious anemia have not been carried out yet. Thus the B-12 metabolic disturbance may not be the cause of manic-depressive illness in these families, but could enhance its expression.

IV8 initially was resistant to lithium as occurs

in one-fifth of manic-depressive patients. However, the addition of IMI B12 appeared to have a synergistic effect which merits further research. (Workers such as Tisman et al., 1973 and Bloomfield et al., 1973, are looking at relationships between B-12 and lithium.)

The family study also draws attention to the importance of latent pernicious anemia in affective illness. As pointed out earlier (Reading, 1975a, 1975b, and 1975c), where there is a strong family history of affective illness and especially pernicious anemia in three or more generations, occurring with premature graying, with or without autoimmune disease (especially diabetes, rheumatoid arthritis, vitiligo, and thyroid disorder), with or without familial cancer—it is imperative that a B12 assay (and hopefully B-1, B6, and other vitamins) be done regardless of the hemoglobin and blood film. The hemoglobin and film may or may not be normal, and neurological or gastrointestinal symptoms or signs typical of pernicious anemia may also be absent. Confusion is not always present with low B-12 and remissions, and exacerbations are known to occur. The chronic depressive unresponsive to antidepressants, ECT, and a candidate for psychosurgery is at risk for latent pernicious anemia, especially if the above associated conditions are present in the family history. B-12 assays are not usually done if the hemoglobin and film are normal.

In the case of V5, because he had recurrent depression, was red-green colorblind as was his maternal grandfather III3 who in addition had pernicious anemia and affective illness (bipolar), it was predicted he was very much at risk for pernicious anemia, and as a result he was tested and found to be deficient in B-12-

Thus identification of X-linked metabolic disturbances may not only be very important in the primary, secondary, and tertiary prevention of X-linked manic-depressive illness, but also for the prevention of familial autoimmune disease and familial cancer when these are strongly associated in the manic-depressive family (Reading 1974, 1975a).

**Conclusion**

In the family described, X-linked dominant manic-depressive illness through five generations seems to be associated with X-linked dominant vitamin B12 deficiency through at least four generations linked with Xg blood group and red-green color blindness. Such an association has not been previously recorded. It is likely the gene site for manic-depressive illness is close to, if not at the same locus as that for low vitamin B-12 metabolic disturbance. Thus manic-depressive illness may well be due to X-linked vitamin B-group dependent states (especially B6, B-1, B-12, and possibly niacin), as B-group vitamin deficiencies commonly occur (80 percent) in manic-depressive illness (Reading, 1975a, 1977, and work to be published, vitamin profiles in manic-depressive illness).

Thus the identification and treatment of inherited metabolic disturbances such as X-linked B-group vitamin deficient-dependent states may in the future play a major role in the primary, secondary, and tertiary prevention of manic-depressive illness (as well as other affective disorders) and may explain many of the mysteries still surrounding this common, often psychologically crippling and potentially lethal (due to suicide) condition.

**Acknowledgments**

I gratefully acknowledge the cooperation of the family who participated in this study.

I also thank the following people for their much appreciated assistance:

Mrs. Jean Hough and Mrs. Sharon Rear-don for secretarial assistance. Dr. A. McLeay, formerly of Oliver Latham Laboratory, North Ryde, NSW. Miss M. M. Leeman, Department of Psychiatry, University of Sydney. Dr. S. Nobile, Chief Chemist (now retired) and Miss P. Rosevear, the Vitamin Laboratories. Roche Products Pty. Ltd., Dee Why, for performing

vitamin assays. Mr. J. Ruxton, Oliver Latham Laboratory, North Ryde, NSW, for Xga blood grouping. Dr. B. Arnold, formerly of Ljdcome State Laboratories, NSW. Professor C. B. Kerr of the Genetic Department in the School of Public Health and Tropical Medicine, Sydney University, NSW. Miss A. Thomas, for the loan of the Comprehensive Lithium Index. The staff of Ward 5, North Ryde Psychiatric Centre, NSW, especially Mr. R. Hunter (formerly Charge Nurse of Ward 5). Dr. D. M. Storey, Commissioner for\* Environmental and Special Health Services, for permission to publish this article.

**REFERENCES**

BAR, J.: *The Functions of the Vitamins: Apoltonia-Verlag Basle, Switzerland, 1969.*

BLOOMFIELD, J., SCOTT, J., HERBERT, V., and STEBBINS, R.: Human Serum Unsaturated B<sub>12</sub> Binding Increases with Increase of Length of in vitro Presence of Granulocytes and Certain Anticoagulants, Especially those Containing Lithium. *Fed. Proc.* 32: (3pt):892,1973.

De GRUCHY, G. C: *Clinical Hematology, 2nd Edition. Blackwell Scientific Publications, Oxford, 135,1966.*

FIEVE, R. R., MENDEWICZ, J., and FLEISS, J. L: Manic-Depressive Illness: Linkage with Xg Blood Group. *Am. J. Psychiat.* 130:12, 1355, 1973.

FURUHJELM, U, and NEVANLINNA, H. R.: Inheritance of Selective Malabsorption of Vitamin B-<sub>12</sub>. *Scand. J. Haemat.* 11:26,1973.

HAWKINS, D., and PAULING, L: *Orthomolecular Psychiatry: Treatment 7—of Schizophrenia. W. H. Freeman and Co., San Francisco, 216,1973.*

HOHN, D. C, and LEHRER, R. I.: NADPH oxidase deficiency in X-linked Chronic Granulomatous Disease. *J. Clin. Investig.* 55:707,1975.

HORRIGAN, D. L, and HARRIS, J. W.: Pyridoxine-Responsive Anemia: Analysis of Sixty-one Cases. *Adv. Intern. Med.* 12:103,1964.

MENDEWICZ, J., and FLEISS, J. L: Linkage Studies and X-chromosome Markers in Bipolar (Manic-Depressive) and Unipolar (Depressive) Illness. *Biolog. Psychiat.* 9,3:261,1974. PERRY, T. L, BRATTY, P. J. A., HANSEN, S., and KENNEDY, J.: Hereditary Mental Depression and Parkinsonism with Taurine Deficiency. *Arch. Neurol.* 32:108,1975. READING, C. M.: Report on NSW State Cancer Council for year ended 30th June, 1974, No. 89,37,1974. READING, C. M.: Latent Pernicious Anemia: A Preliminary Study. *Med. J. Aust.* 1:1:91,1975a. READING, C. M.: Latent Pernicious Anemia: *Med. J. Aust.* 1:430, 1975b. READING, C. M.: Latent Pernicious Anemia: *Med. J. Aust.* 2:111, 1975c. READING, C. M.: Psychosurgery, Orthomolecular Psychiatry and the Press. *Med. J. Aust.* 1:642,1977. RENWICK, J. H., and SCHULZE, J.: An Analysis of Some Data on the Linkage between the Xg Blood Group and Color-Blindness in Mati. *Am. J. Human Genet.* 16:410,1964.

SLATER, E., and ROTH, M.: *Vitamin B<sub>12</sub> Deficiency in Clinical Psychiatry, 3rd Edition. Bailliere, Tindale and Cassell, London -355 1969.*

TISMAN, G., HERBERT, V., and ROSENBLATT, S.: Evidence that lithium induces human granulocyte proliferation. Elevated serum vitamin B<sup>12</sup> binding capacity in vivo and granulocyte colony proliferation in vitro. *Brit. J. Haematol.* 24 (6): 767,1973.

WHITLOCK, F. A.: *Mental Health Congress: 25th Meeting. In: "MD. Australia," Vol. 4, No. 2, Feb. p. 16,1974.*

WINOKUR, G., CLAYTON, P. J., and REICH, T.: *Manic-Depressive Illness. C. V. Mosby and Co. Publishers, St. Louis, 1969.*

WINOKUR, G., and TSUANG, M.: The Iowa 500: Suicide in Mania, Depression and Schizophrenia. *Am. J. Psychiat.* 132:6,630,1975.